

Elsevier Editorial System(tm) for Applied Radiation and Isotopes
Manuscript Draft

Manuscript Number: ARI-D-13-00824R2

Title: Application of the Monte Carlo efficiency transfer method to an HPGe detector with the purpose of environmental samples measurement

Article Type: Full Length Article

Section/Category: Radioactivity and Radiation Measurements

Keywords: HPGe detector, Monte Carlo, efficiency transfer, low-background gamma spectrometry

Corresponding Author: Mr. Yasser Morera Gómez, M.D

Corresponding Author's Institution: Centro de Estudios Ambientales de Cienfuegos

First Author: Yasser Morera Gómez, M.D

Order of Authors: Yasser Morera Gómez, M.D; Hector A Cartas Águila, M.D; Carlos M Alonso Hernández, Dr; Jose L Bernal Castillo, M.D; Aniel Guillén Arruebarrena, Bachelor

Manuscript Region of Origin: CUBA

Abstract: Monte Carlo efficiency transfer method was used to determine the full energy peak efficiency of a coaxial n-type HPGe detector. The efficiencies calibration curves for three Certificate Reference Materials were determined by efficiency transfer using a ^{152}Eu reference source. The efficiency values obtained after efficiency transfer were used to calculate the activity concentration of the radionuclides detected in the three materials, which were measured in a low-background gamma spectrometry system. Reported and calculated activity concentration show a good agreement with main deviations of 5%, which is satisfactory for environmental samples measurement.

Highlights

- We use the Monte Carlo code MCNPX to build an HPGe detector model.
- The efficiency transfer method allowed the efficiency calibration of the detector.
- We calculated the activity concentration for three Certificated Reference Materials.
- The reported and calculated activities show a good agreement with main deviations of 5%.

1
2
3
4 **Application of the Monte Carlo efficiency transfer method to an HPGe**
5 **detector with the purpose of environmental samples measurement.**
6
7

8
9 Yasser Morera-Gómez^a; Héctor A. Cartas-Aguila^a; Carlos M. Alonso-Hernández^a; Jose L.
10 Bernal-Castillo^b; Aniel Guillén-Arruebarrena^a
11
12

13
14 ^aCentro de Estudios Ambientales de Cienfuegos, AP 5. Ciudad Nuclear, CP 59350,
15 Cienfuegos, Cuba.
16
17

18
19 ^bInstituto Superior de Tecnologías y Ciencias Aplicadas, “Quinta de los Molinos” Ave.
20 Salvador Allende, esq. Luaces, Plaza de la Revolución, Ciudad de la Habana, CP 10400,
21 Cuba.
22
23

24
25 Corresponding Author: Yasser Morera-Gómez
26

27
28 yasser@ceac.cu
29

30
31 Tel. and fax: +53 43965146.
32

33
34 **1. Abstract**
35

36 Monte Carlo efficiency transfer method was used to determine the full energy peak
37 efficiency of a coaxial n-type HPGe detector. The efficiencies calibration curves for three
38 Certificate Reference Materials were determined by efficiency transfer using a ¹⁵²Eu
39 reference source. The efficiency values obtained after efficiency transfer were used to
40 calculate the activity concentration of the radionuclides detected in the three materials,
41 which were measured in a low-background gamma spectrometry system. Reported and
42 calculated activity concentration show a good agreement with mean deviations of 5%,
43 which is satisfactory for environmental samples measurement.
44
45
46
47
48
49
50

51
52 **Keywords:** HPGe detector, Monte Carlo, efficiency transfer, low-background gamma
53 spectrometry
54
55

56
57 **2. Introduction**
58
59
60
61
62
63
64
65

1
2
3
4
5
6
7
8
9
10
11
12
13
14
15
16
17
18
19
20
21
22
23
24
25
26
27
28
29
30
31
32
33
34
35
36
37
38
39
40
41
42
43
44
45
46
47
48
49
50
51
52
53
54
55
56
57
58
59
60
61
62
63
64
65

The low-background gamma spectrometry with high purity germanium detectors (HPGe) is one of the most widely used procedures to determine the activity concentrations of radionuclides in environmental samples (Pérez-Moreno et al., 2002; Alonso-Hernández et al., 2006; Krmar et al., 2009), because it is a high-resolution and nondestructive technique, that does not require laborious sample preparation. However, it needs prior knowledge of the full energy peak efficiency (FEPE) at each photon energy for the given measurement conditions, which must be obtained by an efficiency calibration using standard radioactive sources of very similar geometrical dimensions, density, and chemical composition, compared to the measured sample. These conditions are not always easy to achieve in many laboratories.

At present, the use of Monte Carlo (MC) simulation is an alternative or complement to experimental efficiency calibrations. However, many authors have reported discrepancies superior to 20% between efficiency values obtained experimentally and by MC simulations based on nominal values of the parameters supplied by the manufacturer (Boson et al., 2008; Budjaz et al., 2009). These differences are mainly due to the inaccuracies of the geometric characteristics of the detector. One effective procedure to overcome these difficulties is to use an efficiency transfer function from a reference geometry to other source configurations, using MC calculations. This procedure consists of calculating the FEPE by mean of an energy dependent transfer factor, which is derived by comparing the direct calculated FEPEs using the manufacturer's detector parameters with the source experimental values at a reference position. In the literature, different authors have reported differences below 10% after using the transfer function (Boson et al., 2008; Jurado Vargas et al., 2003; Liye et al., 2006; Padilla Cabal et al., 2010).

In this paper, we use the MC code MCNPX 2.6 to build an n-type HPGe detector model based on manufacturer supplied data and apply the efficiency transfer method to reproduce reported activity for the radionuclides in three different Certified Reference Materials (CRM). We determine the efficiencies calibration curves for each of these CRM by efficiency transfer and then, we calculate the activity concentrations using the values of these curves. The aim of this work is to show that the MC efficiency transfer method offers a reliable and simple tool to estimate the natural radioactive levels in samples of different

1
2
3
4 compositions and different geometries, so this method can be implemented to improve the
5 efficiency calibration in the laboratory.
6
7

8 9 **3. Experiments and method**

10 11 *3.1. Detector*

12
13 The HPGe detector considered in this paper is a coaxial n-type detector with an epoxy
14 carbon window; model NGC 3019 from Detector System GmbH (DSG Detector Systems
15 GmbH). The detector has 31.5% of relative efficiency in relation to a NaI(Tl) detector with
16 an active area of 3x3 inches, a resolution (FWHM) of 0.90 keV at 122 keV and 1.84 keV at
17 1332 keV⁶⁰Co. It was coupled to an electronic chain, including a multichannel analyzer
18 (MCA) type TMCA. The spectrum is analyzed using Winner 6.0 software. This detector is
19 surrounded by a cylindrical low-background chamber made with the following elements:
20 240 mm of steel, 37 mm of lead, 1 mm of aluminum and 1 mm of copper from outside to
21 the inner region. This spectrometric system is used in the Environmental Study Centre of
22 Cienfuegos (CEAC), Cuba to determine the activity concentrations of radionuclides in
23 environmental samples. The dimensions and materials of the detector provided by
24 manufacturers are shown in Fig. 1. These characteristics were used to model the detector
25 in the simulation process. Monte Carlo software for HPGe detectors efficiency calculation
26 was MCNPX 2.6.
27
28
29
30
31
32
33
34
35
36
37
38
39

40 41 *3.2. Monte Carlo efficiency transfer method*

42
43 In order to correct differences between efficiency values obtained experimentally and by
44 MC simulations based on nominal values of the parameters supplied by the manufacturer,
45 we use an energy-dependent transfer factor. It is founded on the assumption that the
46 transfer factors between Monte Carlo computed FEPEs using the initial detector data and
47 measurement values are dependent on photon energy only, independent of geometry
48 configurations (Lépy et al., 2001; Piton et al., 2000). The efficiency for a particular
49 geometry ε_x is then given by
50
51
52
53
54
55

$$56 \quad \varepsilon_x = \varepsilon_{ref} \left(\frac{\varepsilon_x^{MC}}{\varepsilon_{ref}^{MC}} \right) \quad (1)$$

57
58
59
60
61
62
63
64
65

1
2
3
4 where ε_{ref} is the experimental efficiency for a reference case, and ε_{ref}^{MC} and ε_x^{MC} are
5 calculated efficiencies (via Monte Carlo) for the reference case and the geometry of
6 interest, respectively. All these values are referred to a given energy.
7
8
9

10 For the reference geometry, we measured a standard source of ^{152}Eu with 42.83 kBq of
11 activity. It was placed at 32 cm from the Al front end cap of the detector in order to avoid
12 summing effects and minimize the dead time. The standard was a silicone resin ($V = 196.0$
13 $\pm 1.96 \text{ cm}^3$ and $\rho = 0.98 \pm 0.01 \text{ g/cm}^3$) with a composition of the matrix: C – 0.324, H –
14 0.0816, O – 0.216 and Si – 0.379 (mass ratio) and 42.83 kBq of activity. It was included in
15 a cylindrical container of polystyrene of 1 mm thickness with an internal diameter of 50 mm
16 and filling height of 98 mm. The standard of ^{152}Eu covers the energy range 40 – 1408 keV
17 and the values are given for the reference date 15 July 2010.
18
19
20
21
22
23
24
25

26 Applying the equation (1), we computed the efficiency values for three samples-to-detector
27 configurations: 70 g of the Certified Uranium-Thorium Reference Ore DL-1a contained in a
28 polystyrene capsule (1.8 mm thickness and 72 mm of internal diameter) with an estimated
29 density of $\rho = 1.22 \pm 0.09 \text{ g/cm}^3$, 70 g of the Certified Reference Material (CRM) soil IAEA-
30 375 contained in a similar capsule with an estimated density of $\rho = 1.59 \pm 0.12 \text{ g/cm}^3$ and
31 25 g of the Certified Reference Material, Uranium Ore IAEA-RGU-1 contained in a
32 polystyrene capsule (1.2 mm thickness and 56.6 mm of internal diameter) with an
33 estimated density of $\rho = 1.22 \pm 0.09 \text{ g/cm}^3$. In order to implement the matrices of DL-1a
34 and IAEA-RGU-1 during the MC simulation processes, we used the chemical composition
35 reported for DL-1a (Steger and Bowman, 1980). A standard soil was used for the IAEA-
36 375 material (Wielopolski et al., 2005).
37
38
39
40
41
42
43
44
45
46
47

48 3.3. *Experimental measurements*

49

50 Before analysis the samples were sealed and kept for three weeks approximately, to
51 ensure that secular equilibrium between ^{226}Ra and radon daughters had been achieved.
52 The three samples were measured in the low-background system described above;
53 placing the samples over the front end cap of the detector. The activity concentrations A_x
54 of the radionuclides detected in the three CRM were calculated by the equation
55
56
57
58
59
60
61
62
63
64
65

$$A_x = \frac{T_x}{\gamma \varepsilon_x m_x} e^{-\lambda t} \quad (2)$$

where T_x is the experimental counts rate (s^{-1}), γ is the gamma decay probability, m_x is the sample mass (g), λ is the decay constant, t is the time elapsed between the reference date and the measurement date, and ε_x is the efficiency after transfer function application, given by the equation (1).

^{226}Ra activity of the samples was determined via its daughters ^{214}Pb and ^{214}Bi . The ^{232}Th activity was determined from the activity of ^{212}Bi , ^{212}Pb and ^{228}Ac . In both cases the activity concentration computed for each line individually were quite similar. The routine quality control in our laboratory has shown us that the activity values of ^{226}Ra and ^{232}Th , reported for the CRM used in this study, are reproducible when we use the efficiency curve obtained in this work. Therefore, we decided not to take into account the summing effect for the used geometries.

The ^{228}Th and ^{238}U activities were determined from the activity of ^{208}Tl (583.2 keV) and ^{234}Th (63.3 keV), respectively. Finally, to determine ^{40}K , ^{137}Cs and ^{210}Pb activities, the well-known 1460.75, 661.7 and 46.54 keV lines were used, respectively.

Relatives uncertainties (u) were calculated using the law of uncertainty propagation taking into account all the variables involved in the equation (1) and (2).

$$u(A_x) = \sqrt{u^2(T_x) + u^2(\varepsilon_x) + u^2(\gamma) + u^2(m_x)} \quad (3)$$

$$u(\varepsilon_x) = \sqrt{u^2(\varepsilon_{ref}) + u^2(\varepsilon_{ref}^{MC}) + u^2(\varepsilon_x^{MC})} \quad (4)$$

$$u(\varepsilon_{ref}) = \sqrt{u^2(T_{ref}) + u^2(A_{ref}) + u^2(\gamma) + u^2(m_{ref})} \quad (5)$$

Where T_{ref} , m_{ref} and A_{ref} are the experimental counts rate, the sample mass, and the activity of ^{152}Eu reference source, respectively.

4. Results and discussion

1
2
3
4
5
6
7
8
9
10
11
12
13
14
15
16
17
18
19
20
21
22
23
24
25
26
27
28
29
30
31
32
33
34
35
36
37
38
39
40
41
42
43
44
45
46
47
48
49
50
51
52
53
54
55
56
57
58
59
60
61
62
63
64
65

Fig. 2 shows the comparisons between the measured peak efficiencies and the direct MC calculated efficiencies using manufacturer's data for ^{152}Eu reference source; as well as the efficiency curves for the three CRM after transfer calculation. The discrepancies observed between the experimental and calculated efficiencies for the reference source even exceed the 50%. As has been reported by numerous authors (Elanique et al., 2012; Laborie et al., 2000; Ródenas et al., 2003), this disagreement is usual when detector manufacturer data are used directly, because significant deviations in the efficiency can occur from only slight changes in some of the detector geometrical parameters. An improved performance can be obtained after application the efficiency transfer method. This method corrects the geometric differences and also includes a correction for the intrinsic detector efficiency, thus, is not necessary to make corrections in the low energy ranges because the self-absorption is taken into account in the MC simulation of the sample of interest.

The results obtained by performing the efficiency transfer from the reference geometry to the three CRM (solid lines in Fig. 2) were used to calculate the activity concentrations of the radionuclides detected in these matrices. Table 1 gives the comparison between reported and calculated activity concentration. Results show a good agreement for all the radionuclides, which are distributed throughout the energy range we studied here. The mean deviation between reported and calculated activity concentration is 5% and the biggest deviation are observed for ^{238}U and ^{226}Ra in the CRM IAEA-375 and for ^{210}Pb in the CRM DI-1a.

The environmental samples measurement requires an accurate efficiency calibration in the energy range of interest; therefore it is necessary to have standard radioactive sources that cover the energy range of study. The reference source used in this work (^{152}Eu) for efficiency transfer has the majority of analytical lines above 100 keV, and we use only the analytical line of 45.5 keV in the low energy region, which may result in an interpolation quality decreased in this region. For example, the results for the activity concentration of ^{238}U and ^{210}Pb in the CRM DI-1a shows a difference of 16 % and 5 % respect to the reported value, respectively. However, these all these results obtained here do not show significant differences with the reported values if we take in to account the measurement

1
2
3
4
5
6
7
8
9
10
11
12
13
14
15
16
17
18
19
20
21
22
23
24
25
26
27
28
29
30
31
32
33
34
35
36
37
38
39
40
41
42
43
44
45
46
47
48
49
50
51
52
53
54
55
56
57
58
59
60
61
62
63
64
65

uncertainties (Linsinger, 2005). To use standard point radioactive sources covering the whole energy range under study, can be an alternative when the Monte Carlo efficiency transfer method is applied (Jurado Vargas et al., 2003; Padilla Cabal et al., 2010).

As we can see, the application of the MC efficiency transfer method gives reliable results when complex matrices such as environmental samples are studied. Then, this method can be used in the laboratory as an excellent tool in the efficiency calibrations processes, mainly when we do not have standard radioactive sources of similar density and chemical composition to the studied sample.

5. Conclusions

The application of the Monte Carlo efficiency transfer method for efficiency calibration of an n-type HPGe detector, allowed us to determine activities in environmental samples. The peak efficiency calculated by direct Monte Carlo calculation using the manufacturer's detector parameters showed significant discrepancies with respect to the experimental values. However, after applications of efficiency transfer method we found a good agreement between calculated and reported activity concentrations for three Certified Reference Materials with mean deviations of 5%. Therefore, this method can be used in the laboratory to improve the efficiency calibrations of the HPGe detector. Now, we have a simple and effective method for routine measurement purpose in our laboratory, based on the Monte Carlo simulation with nominal parameters of the detector supplied by the manufacturer.

Acknowledgements

This research work was undertaken in the framework of the IAEA TC Project CUB/7/008 "Strengthening the National System for Analysis of the Risks and Vulnerability of Cuba's Coastal Zone through the Application of Nuclear and Isotopic Techniques". The authors will like to acknowledge the EJDS program at ICTP.

References

Alonso-Hernández, C.M., Cartas Águila, H., Diaz-Asencio, M., Muños-Caravaca, A., Martín-Pérez, J., Sibello-Hernández, R., 2006. Atmospheric deposition of ¹³⁷Cs between 1994 and 2002 at Cienfuegos, Cuba. J. Environ. Radioact. 88, 199–204.

- 1
2
3
4 Boson, J., Agren, G., Johansson, L., 2008. A detailed investigation of HPGe detector
5 response for improved Monte Carlo efficiency calculations. Nucl. Instrum. Methods
6 Phys. Res. A 587, 304–314.
7
8
9 Budjaz, D., Heisel, M., Maneschg, W., Simgen, H., 2009. Optimisation of the MC-model of
10 a p-type Ge-spectrometer for the purpose of efficiency determination. Appl. Radiat.
11 Isot. 67, 706–710.
12
13 DSG Detector Systems GmbH: <http://www.detector-systems.de>
14
15
16 Elanique, A., Marzocchi, O., Leone, D., Hegenbart, L., Breustedt, B., Oufni, L., 2012. Dead
17 layer thickness characterization of an HPGe detector by measurements and Monte
18 Carlo simulations. Appl. Radiat. Isot. 70, 538–542.
19
20
21 Jurado Vargas, M., Cornejo Díaz, N., Pérez Sánchez, D., 2003. Efficiency transfer in the
22 calibration of a coaxial p-type HPGe detector using the Monte Carlo method. Appl.
23 Radiat. Isot. 58, 707–712.
24
25
26 Krmar, M., Radnovi, D., Mihailovi, D.T., Lali, B., Slivka, J., Bikit, I., 2009. Temporal
27 variations of ^7Be , ^{210}Pb and ^{137}Cs in moss samples over 14 month period. Appl.
28 Radiat. Isot. 67, 1139–1147.
29
30
31 Laborie, J.M., Le Petit, G., Abt, D., Girard, M., 2000. Monte Carlo calculation of the
32 efficiency calibration curve and coincidence-summing corrections in low-level
33 gamma-ray spectrometry using well-type HPGe detectors. Appl. Radiat. Isot. 53,
34 57–62.
35
36
37 Lépy, M.C., Altitzoglou, T., Arnold, D., Bronson, F., Noy, R.C., Décombaz, M., De Corte,
38 F., Edelmaier, R., Peraza, E.H., Klemola, S., Korun, M., Kralik, M., Neder, H.,
39 Plagnard, J., Pommé, S., de Sanoit, J., Sima, O., Ugletveit, F., Van Velzen, L.,
40 Vidmar, T., 2001. Intercomparison of efficiency transfer software for gamma-ray
41 spectrometry. Appl. Radiat. Isot. 55, 493–503.
42
43
44 Linsinger, T., 2005. Comparison of a measurement result with the certified value.
45 Application Note 1. European Commission-Joint Research Centre Institute for
46 Reference Materials and Measurements (IRMM).
47
48
49 Liye, L., Jizeng, M., Franck, D., de Carlan, L., Binqun, Z., 2006. Monte Carlo efficiency
50 transfer method for full energy peak efficiency calibration of three type HPGe
51 detectors: A coaxial N-type, a coaxial P-type and four BEGe detectors. Nucl.
52 Instrum. Methods Phys. Res. A 564, 608–613.
53
54
55 Padilla Cabal, F., Lopez-Pino, N., Luis Bernal-Castillo, J., Martinez-Palenzuela, Y.,
56 Aguilar-Mena, J., D'Alessandro, K., Arbelo, Y., Corrales, Y., Diaz, O., 2010. Monte
57 Carlo based geometrical model for efficiency calculation of an n-type HPGe
58 detector. Appl. Radiat. Isot. 68, 2403–2408.
59
60
61
62
63
64
65

1
2
3
4
5
6
7
8
9
10
11
12
13
14
15
16
17
18
19
20
21
22
23
24
25
26
27
28
29
30
31
32
33
34
35
36
37
38
39
40
41
42
43
44
45
46
47
48
49
50
51
52
53
54
55
56
57
58
59
60
61
62
63
64
65

Pérez-Moreno, J.P., San Miguel, E.G., var, J.P., Aguado, J.L., 2002. A comprehensive calibration method of Ge detectors for low-level gamma-spectrometry measurements. Nucl. Instrum. Methods Phys. Res. A 491, 152–162.

Piton, F., Lépy, M.-C., Bé, M.-M., Plagnard, J., 2000. Efficiency transfer and coincidence summing corrections for gamma-ray spectrometry. Appl. Radiat. Isot. 52, 791–795.

Ródenas, J., Pascual, A., Zarza, I., Serradell, V., Ortiz, J., Ballesteros, L., 2003. Analysis of the influence of germanium dead layer on detector calibration simulation for environmental radioactive samples using the Monte Carlo method. Nucl. Instrum. Methods Phys. Res. A 496, 390–399.

Steger, H.F., Bowman, W.S., 1980. DL-1a: A Certificated Uranium-Thorium Reference Ore (No. 80-10E). CANMET report.

Wielopolski, L., Song, Z., Orion, I., Hanson, A.L., Hendrey, G., 2005. Basic considerations for Monte Carlo calculations in soil. Appl. Radiat. Isot. 62, 97–107.

Table 1. Comparisons between reported activity concentrations for radionuclides detected in three Certified Reference Materials and calculated activity concentration with efficiency transfer function.

Sample	Isotopes	Reported ^a	Calculated after transfer ^a	Ratio between calculated and reported value
DL-1a (Bq/g)	²¹⁰ Pb	1.40 ± 0.01	1.47 ± 0.06	1,05
	²²⁶ Ra	1.40 ± 0.02	1.41 ± 0.04	1,01
IAEA-375 (Bq/kg)	⁴⁰ K	424 ± 8	430 ± 20	1,01
	¹³⁷ Cs	5280 ± 80	5224 ± 160	0,99
	²²⁶ Ra	20 ± 2	22.9 ± 2.0	1,15
	²²⁸ Th	21 ± 4	22.3 ± 2.0	1,06
	²³² Th	20.5 ± 1.4	20.7 ± 1.7	1,01
	²³⁸ U	24.4 ± 5.4	20.4 ± 7.0	0,84
IAEA-RGU-1 (Bq/kg)	²¹⁰ Pb	4940 ± 30	4886 ± 231	0,99
	²²⁶ Ra	4940 ± 30	5081 ± 162	1,03

^aAll uncertainties are reported with 95% confidence level.

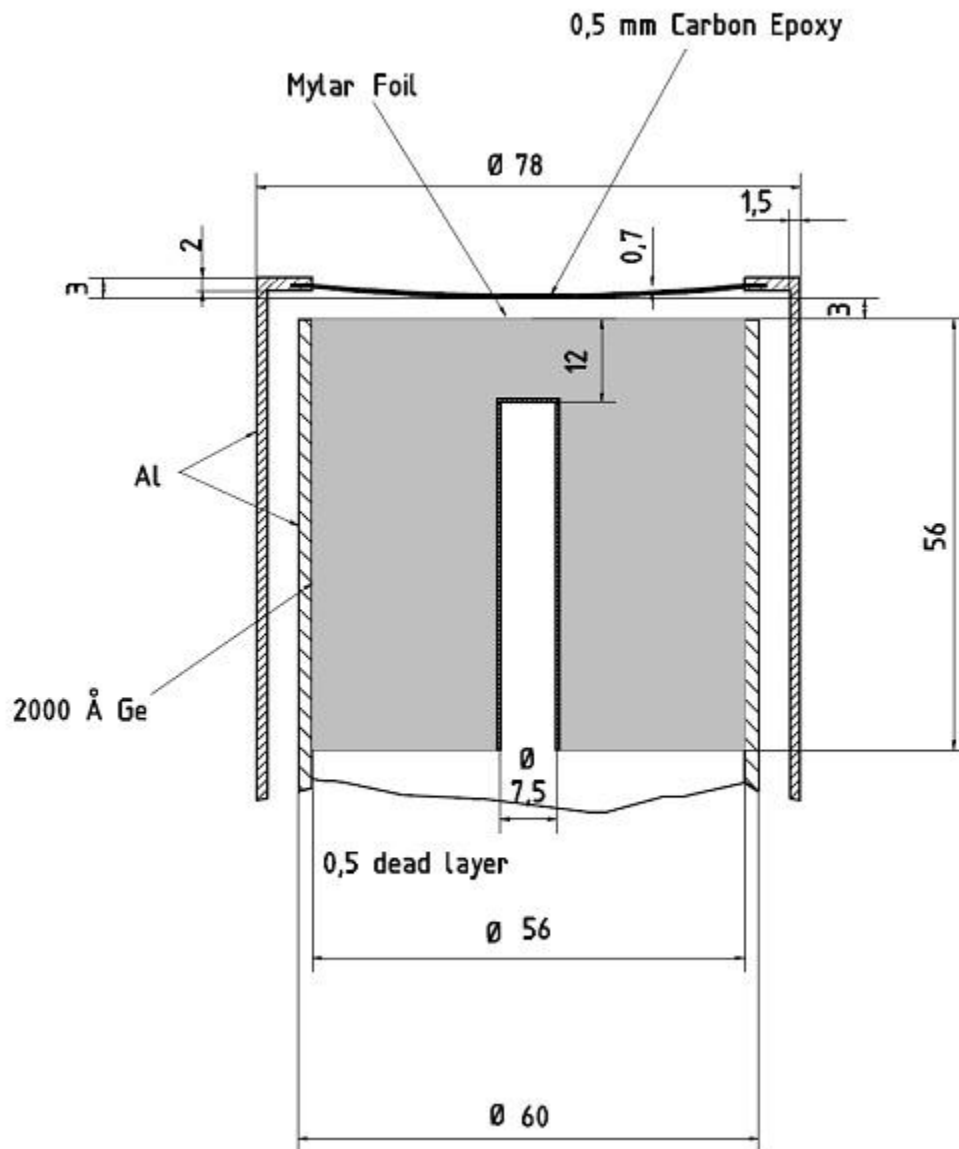

Fig. 1. Cross-section of the detector with the dimensions and materials provided by the manufacturers.

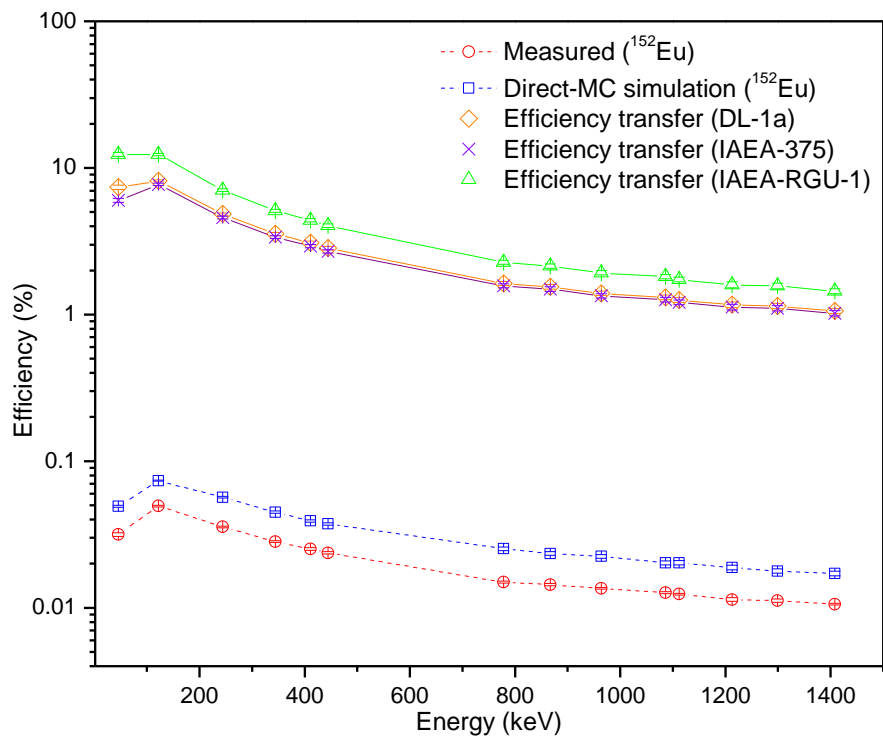

Fig. 2. Measured and computed (MCNPX) photo-peak efficiency. The dotted lines correspond to the experimental efficiency for the reference source and the calculated efficiency by direct MC simulation using the nominal parameters of the detector. The solid lines represent the efficiency after application the efficiency transfer.